

ascott

Salt Spray Chambers
Cyclic Corrosion Test Chambers

<http://www.ascott-analytical.com/>

120 L
(4.2 ft³)

S120s
S120+
S120xp



450 L
(16 ft³)

S450s
S450+
S450xp
CC450xp



1000 L
(35 ft³)

S1000s
S1000+
S1000xp
CC1000xp



2000 L
(71 ft³)

S2000s
S2000+
S2000xp
CC2000xp



- Accessible** 31" above floor
- No leaning/ no stretching
 - No access ramps
- Clean** Dry seals and vent cycle
- No damaged rooms
 - No ruined clothing
 - Use as display lab

- Durable** Marine-grade fiberglass
- No corroded walls
 - No annual rust scraping

- Adaptable** Easy set up
- Icon based programming of complex standards
 - Does almost all test standards including G84 Anx4 SO₂ fog testing

s (standard)

+ (plus)

xp (premium)

Salt Spray Testing

Complies

ASTM B117, etc

- Timed stop
- Hours counter
- 2 line display
- Push button controls



All 's' features + Condensation RH Testing

Complies

All 's' standards and D2247, etc.

- Provides testing for spray, condensation humidity
- Relative humidity display
- 2 line display with Keypad entry

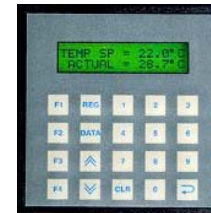

All '+' features with programmed cycles and run-time display

Complies

All salt spray standards;

S – All '+' standards

and ASTM G85 Anx A2,3,4,5;
G85 Anx 4 with SO₂ option

CC – also SAE J2334, GM9540,
many, many more ...

- Multi step testing all machines, cycle between test modes
- *Salt Spray* – Cycle between spray and RH modes
- *CCT* – Automatic cycling between complex test steps, controlled RH testing, fully comply with international cyclic corrosion test standards
- Touch screen control, icon programming graphical display of set point and actual values



Rent / Lease / Lease-to-buy

- Preserve the capital budget
- Protect the P&L from excess capital costs

... and get the chamber of your choice

Ask about Comtel's rental and leasing programs!

S = Salt Spray Test
CC = Cyclic Corrosion Test

Call Comtel 800-335-2505

Contact: Charles Armentrout,
carmentrout@comtel.com

North American Distributor



Comtel Corporation

39830 Grand River Avenue, Suite B-1A
Novi, MI 48375

Phone: 800-335-2505

Fax: 248-888-4743 www.comtel.com

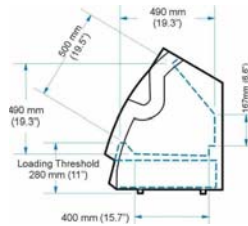

Ascott S120

bench-top salt spray chamber

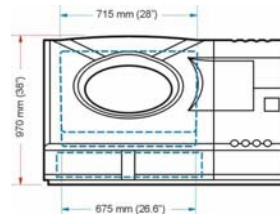

Ascott S450 / CC450

Salt / cyclic corrosion chamber

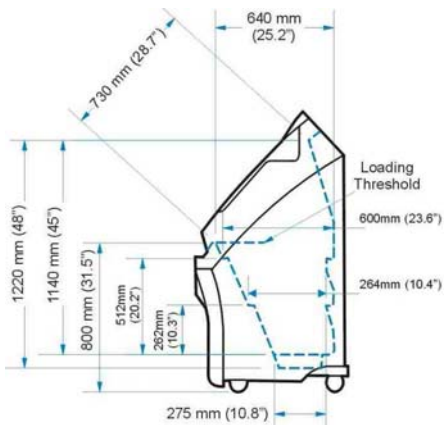

Ascott S1000 / CC1000

Salt / cyclic corrosion chamber

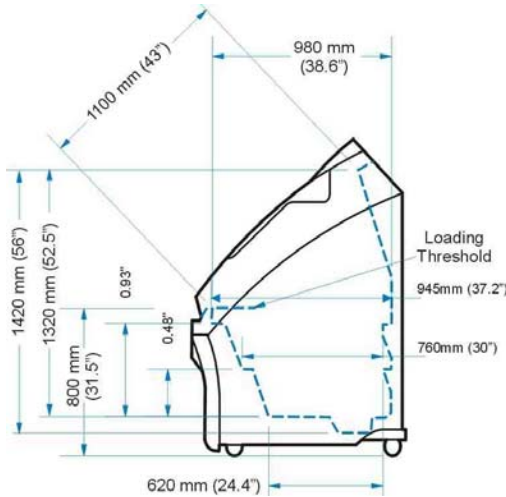

Ascott S2000 / CC2000

Salt / cyclic corrosion chamber

